



Modular Cooking Range Line 700XP Gas Solid Top on Gas Oven with 2 Burners

ITEM # _____

MODEL # _____

NAME # _____

SIS # _____

AIA # _____



371009 (E7STGH30G0)

700XP GAS SOLID TOP ON
GAS OVEN WITH 2
BURNERS - LPG/NATURAL
GAS

Short Form Specification

Item No. _____

High efficiency 3.8 kW central burner, flame failure device and protected pilot light. Suitable for natural gas or LPG. Large cooking surface with different heating zones. Large flat cooking surface made in cast iron allows for the use of a number of various sized pots and pans, all easily moved across the surface without lifting. Stainless steel oven chamber with 3 levels of runners to accommodate 2/1 GN shelves (2 steam pans). Two high efficiency 5,5 kW flower flame burners with continuous power regulation and protected pilot light interchangeable on site. Flame failure device as standard on burners to protect against accidental extinguishing. Exterior panels in stainless steel with Scotch Brite finish. One piece pressed work top in 1.5 mm thick stainless steel. Right-angled side edges to allow flush-fitting junction between units.

Main Features

- Gas heated, 3.8 kW central burner, solid top.
- Durable cast iron cooking plate, easy to clean.
- The center of the plate can reach a maximum temperature of 500 °C while decreasing outwards.
- Central burner with optimized combustion, flame failure device and protected pilot light.
- Temperature gradients to satisfy different cooking needs, provided over the whole plate thanks to the temperature fine-tuning by zone.
- Various sizes of pans can be used at the same time due to large surface area with no intermediate sectors.
- Pans can easily be moved from one area to another without lifting.
- Base compartment consists of a gas heated standard oven with stainless steel burners and self stabilizing flame positioned beneath the base plate. Stainless steel oven chamber to have 3 levels of runners to accommodate 2/1 GN shelves (2 steam pans) and rib
- Oven thermostat adjustable from 110 °C to 270 °C.
- Burners with optimized combustion interchangeable on site.
- Flame failure device on each burner protects against gas leakage when accidental extinguishing of the flame occurs.
- All major compartments located in front of unit for ease of maintenance.

Construction

- All exterior panels in Stainless Steel with Scotch Brite finishing.
- One piece pressed 1.5 mm work top in Stainless steel.
- Model has right-angled side edges to allow flush fitting joints between units, eliminating gaps and possible dirt traps.
- IPx4 water protection.

Included Accessories

- 1 of GN2/1 chrome grid for static oven PNC 164250

Optional Accessories

- GN2/1 chrome grid for static oven PNC 164250
- Junction sealing kit PNC 206086
- Draught diverter with 150mm diameter PNC 206132
- Matching ring for flue condenser PNC 206133

APPROVAL: _____



Experience the Excellence
www.electroluxprofessional.com

• 4 wheels, 2 swivelling with brake (700/900XP). It is mandatory to install with base supports for feet/wheels.	PNC 206135	<input type="checkbox"/>	• Kit town gas nozzles (G150) for 700 solid top and burner	PNC 206388	<input type="checkbox"/>
• Flanged feet kit	PNC 206136	<input type="checkbox"/>	• Chimney grid net, 400mm	PNC 206400	<input type="checkbox"/>
• Frontal kicking strip for concrete installation, 800mm	PNC 206148	<input type="checkbox"/>	• - NOT TRANSLATED -	PNC 206461	<input type="checkbox"/>
• Frontal kicking strip for concrete installation, 1000mm	PNC 206150	<input type="checkbox"/>	• 2 side covering panels, h=700mm, d=700mm	PNC 216000	<input type="checkbox"/>
• Frontal kicking strip for concrete installation, 1200mm	PNC 206151	<input type="checkbox"/>	• Frontal handrail 800mm	PNC 216047	<input type="checkbox"/>
• Frontal kicking strip for concrete installation, 1600mm	PNC 206152	<input type="checkbox"/>	• Frontal handrail 1200mm	PNC 216049	<input type="checkbox"/>
• Frontal kicking strip, 800mm (not for refr-freezer base)	PNC 206176	<input type="checkbox"/>	• Frontal handrail 1600mm	PNC 216050	<input type="checkbox"/>
• Frontal kicking strip, 1000mm (not for refr-freezer base)	PNC 206177	<input type="checkbox"/>	• Large handrail - portioning shelf, 800mm	PNC 216186	<input type="checkbox"/>
• Frontal kicking strip, 1200mm (not for refr-freezer base)	PNC 206178	<input type="checkbox"/>	• Pressure regulator for gas units	PNC 927225	<input type="checkbox"/>
• Frontal kicking strip, 1600mm (not for refr-freezer base)	PNC 206179	<input type="checkbox"/>			
• 4 feet for concrete installation	PNC 206210	<input type="checkbox"/>			
• Flue condenser for 1 module, 150 mm diameter	PNC 206246	<input type="checkbox"/>			
• Pair of side kicking strips	PNC 206249	<input type="checkbox"/>			
• Single burner smooth plate for direct cooking - fits frontal burners only	PNC 206260	<input type="checkbox"/>			
• Single burner ribbed plate for direct cooking- fits frontal burners only	PNC 206261	<input type="checkbox"/>			
• Single burner radiant plate for pan support	PNC 206264	<input type="checkbox"/>			
• Pair of side kicking strips for concrete installation	PNC 206265	<input type="checkbox"/>			
• Water coulumn with swivel arm (water column extension not included)	PNC 206289	<input type="checkbox"/>			
• Water column extension for 700 line	PNC 206291	<input type="checkbox"/>			
• Stainless steel double grid for 2 burners	PNC 206297	<input type="checkbox"/>			
• Chimney upstand, 800mm	PNC 206304	<input type="checkbox"/>			
• Right and left side handrails	PNC 206307	<input type="checkbox"/>			
• BACK HANDRAIL 800 MM - MARINE	PNC 206308	<input type="checkbox"/>			
• Wok pan support for open burners (700/900)	PNC 206363	<input type="checkbox"/>			
• Base support for feet or wheels - 800mm (700/900)	PNC 206367	<input type="checkbox"/>			
• Base support for feet or wheels - 1200mm (700/900)	PNC 206368	<input type="checkbox"/>			
• Base support for feet or wheels - 1600mm (700/900)	PNC 206369	<input type="checkbox"/>			
• Base support for feet or wheels - 2000mm (700/900)	PNC 206370	<input type="checkbox"/>			
• Rear paneling - 800mm (700/900)	PNC 206374	<input type="checkbox"/>			
• Rear paneling - 1000mm (700/900)	PNC 206375	<input type="checkbox"/>			
• Rear paneling - 1200mm (700/900)	PNC 206376	<input type="checkbox"/>			

Front

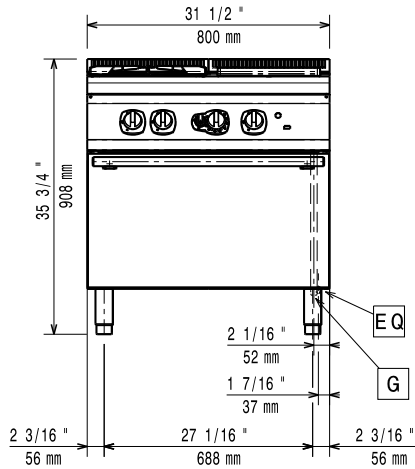

Side

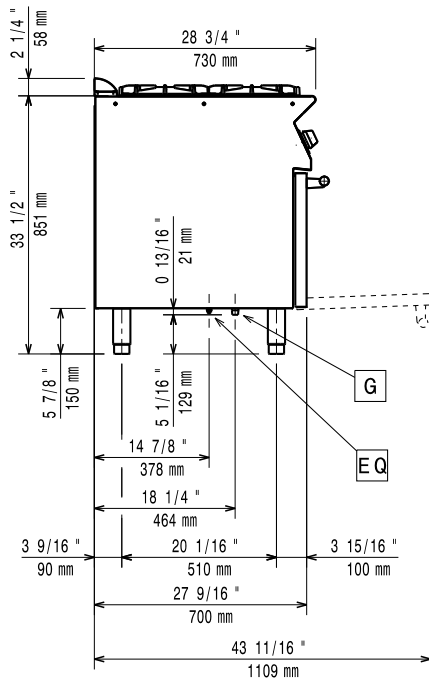

EQ = Equipotential screw
 G = Gas connection

Top

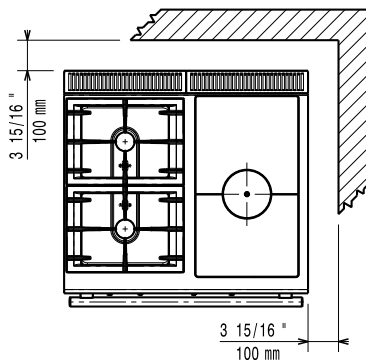

Gas

Gas Power:	20.6 kW
Standard gas delivery:	Natural Gas G20 (20mbar)
Gas Type Option:	LPG
Gas Inlet:	1/2"

Key Information:

If appliance is set up or next to or against temperature sensitive furniture or similar, a safety gap of approximately 150 mm should be maintained or some form of heat insulation fitted.

Oven working Temperature: 110 °C MIN; 270 °C MAX

Oven Cavity Dimensions (width): 540 mm

Oven Cavity Dimensions (height): 300 mm

Oven Cavity Dimensions (depth): 650 mm

Net weight: 90 kg

Shipping weight: 109 kg

Shipping height: 1080 mm

Shipping width: 820 mm

Shipping depth: 860 mm

Shipping volume: 0.76 m³

Front Burners Power: 5.5 - kW

Back Burners Power: 5.5 - 0 kW

Certification group: N7TG

Back Burners Dimension - mm Ø 60

Front Burners Dimension - mm Ø 60

Solid top usable surface (width): 340 mm

Solid top usable surface (depth): 595 mm